

# CONSTANT FORCE SPRINGS



EXTENSION SPRINGS  
SMOOTH RANGE OF MOTION  
MINIMAL STARTING FORCE

PHONE: 516.328.3300 • FAX: 516.326.8827 • WWW.SDP-SI.COM

**> MATERIAL:**

301 Stainless Steel

**> FATIGUE LIFE:**

2500 Cycles Minimum

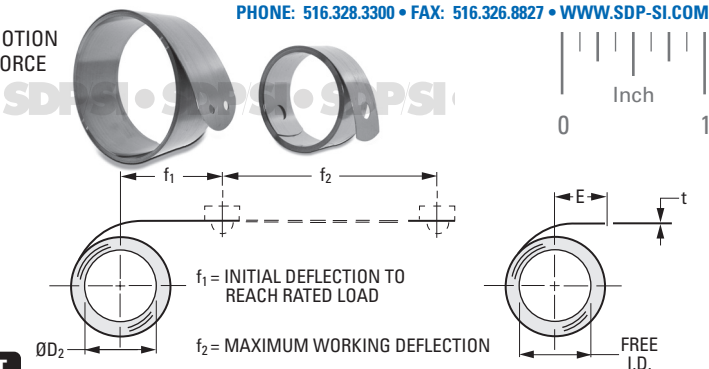

**INCH COMPONENT**

Catalog Number	Load lb $\pm$ 10%	D <sub>2</sub> Drum Dia.*	Free I.D. Ref.	f <sub>1</sub>	f <sub>2</sub>	t Thickness	W Width	Band Length
A 3X50-SH03C10	.37	.261	7/32	.39	8	.003	3/16	10
A 3X50-SH04C14	.49	.349	19/64	.52	12	.004	3/16	14
A 3X50-SH04D14	.66						1/4	
A 3X50-SH04E14	.83						5/16	
Δ A 3X50-SH05E15	1.03	.436	23/64	.65	12	.005	5/16	15
A 3X50-SH06F21	1.48	.523	7/16	.78	18	.006	3/8	21
A 3X50-SH06G21	1.97						1/2	
Δ A 3X50-SH08G28	2.63	.697	37/64	1.06	24	.008	1/2	28
A 3X50-SH08J28	3.29						5/8	
Δ A 3X50-SH10J29	4.12						5/8	
Δ A 3X50-SH10K29	4.95	.873	47/64	1.31	24	.010	3/4	29
A 3X50-SH12K36	5.94						3/4	
A 3X50-SH12P36	7.92	1.050	7/8	1.56	30	.012	3/4	36
A 3X50-SH16P38	10.60						1	
A 3X50-SH20R47	16.50	1.400	1-5/32	2.10	30	.016	1	38
A 3X50-SH20S47	19.80			2.60				
A 3X50-SH25S48	24.80	1.750	1-15/32	2.62	36	.020	1-1/4	47
A 3X50-SH25U48	33.00			2.62				
A 3X50-SH31U58	40.90	2.180	1-53/64	3.27	36	.025	1-1/2	48
		33.00				.025	2	48
A 3X50-SH31U58	40.90	2.710	2-17/64	4.00	42	.031	2	58

\* Drums are not supplied.

Δ Springs have a hole at both ends.

**> MOUNTING HOLE SPECIFICATIONS**

Catalog Number (Ref.)	Fig. No.	E	R Radius	A Dia.	B	C
A 3X50-SH03C10	1	5/32	5/32**	.095	3/32	-
A 3X50-SH04C14			5/32**			
A 3X50-SH04D14		7/32	1/2	.131	3/16	
A 3X50-SH04E14			7/32**			
Δ A 3X50-SH05E15		7/32	1/2	.131	3/16	
A 3X50-SH06F21		1/4	1/2	.191	11/32	
A 3X50-SH06G21						
Δ A 3X50-SH08G28		3/8	7/16	.193	3/8	
A 3X50-SH08J28						
Δ A 3X50-SH10J29		7/16	7/8	1-1/32	.193	
Δ A 3X50-SH10K29						
A 3X50-SH12K36	1/2	3/4	9/16	.193	3/8	
A 3X50-SH12P36						
A 3X50-SH16P38	3/4	7/8	1-1/32	.193	3/8	
A 3X50-SH20R47						
A 3X50-SH20S47	7/8	1-1/8	1-1/32	.256	5/8	.766
A 3X50-SH25S48						
A 3X50-SH25U48	1-1/8	1-1/4	1-1/32	.256	5/8	.766
A 3X50-SH31U58						

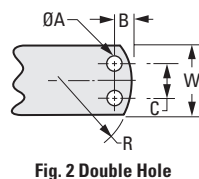
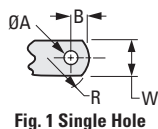

\*\* Fig. 3

Present Radius	Radius Supplied after Present Stock is Depleted
5/32	1/2
7/32	1/2

\*\* To be replaced when present stock is depleted.

1

R

T

1

2

3

4

5

6

7

8

9

10

11

12

13

14

15

16