

SELF-LUBRICATING  
PV 15000 DRY  
REPLACES OILITE AND PLASTIC BEARINGS

PHONE: 516.328.3300 • FAX: 516.326.8827 • WWW.SDP-SI.COM



► MATERIAL:

6061 Aluminum with Frelon® Liner

► INSTALLATION INSTRUCTIONS:

**Option 1 - Slip-Fit**

Slip the bearing sleeve into the housing and epoxy into place with Loctite® or similar type of bonding agent.

**CAUTION:** Do NOT let any of the adhesive touch the bearing liner. It will harden and interfere with the running clearance.

**Option 2 - Press-Fit**

Freeze the bearings at 0°F (-17.78°C) for 30-45 minutes. Using gloves, remove from the freezer and slip the bearings into the housing. As they heat to room temperature, full contact between the bearing and housing will be achieved. The greatest advantage to this technique over traditional pressing is greater accuracy in alignment.

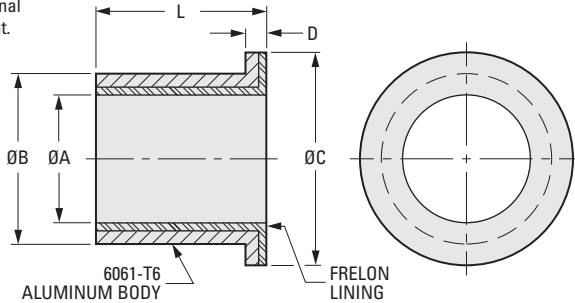
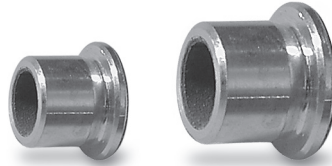

► SPECIFICATIONS:

Recommended Housing Bore		
Catalog Number	Slip-Fit +.001 -.000	Press-Fit +.0005 -.0000
S99PS4-030502	.3145	.3125
S99PS4-040602		
S99PS4-040603	.377	.3750
S99PS4-040604		
S99PS4-061004		
S99PS4-061006	.627	.6250
S99PS4-071006		
S99PS4-081204		
S99PS4-081206	.752	.7500
S99PS4-081208		
S99PS4-101406	.877	.8750
S99PS4-101408		
S99PS4-121608	1.002	.995

INCH COMPONENT

Catalog Number	Nominal			A Bore +.001 -.000	B O.D. +.001 -.000	L Length +.00 -.02	C Flange O.D. Max.	D Flange Thickness Max.
	I.D.	O.D.	Length					
S99PS4-030502	3/16	5/16	1/4	.189	.3135	.25	.437	.125
S99PS4-040602			1/4			.25		
S99PS4-040603	1/4	3/8	3/8	.2515	.376	.375	.500	
S99PS4-040604			1/2			.50		
S99PS4-061004			1/2			.50		
S99PS4-061006	3/8	5/8	3/4	.3765	.626	.75	.875	
S99PS4-071006	7/16	5/8	3/4	.439	.626	.75	.9375	
S99PS4-081204			1/2			.50		
S99PS4-081206			3/4			.75		
S99PS4-081208	1/2	3/4	1	.5015	.751	1.00	1.000	
S99PS4-101406			3/4			.75		
S99PS4-101408	5/8	7/8	1	.6265	.876	1.00	1.000	
S99PS4-121608	3/4	1	1	.7515	1.001	1.00	1.250	

- I
- R
- T
- 1
- 2
- 3
- 4
- 5
- 6
- 7
- 8
- 9
- 10
- 11
- 12
- 13
- 14
- 15
- 16