

A SUPERIOR WAY TO FASTEN ROTATING COMPONENTS

Excelling because of its simplicity, it contains all structural features in only two parts. This new development is the Shaftloc® – a patented device (United States Patent No. 5,067,846 and No. 6,000,875), – manufactured and marketed by Stock Drive Products.

The usefulness of wedges and inclined surfaces for the lifting of heavy loads has been well-known for centuries.

Similarly, the usefulness of tapered, conical surfaces has also been appreciated; in this case, for their ability to produce large forces.

An example of such an application is the use of a tapered cylindrical split bushing (see illustration) to fasten a rotating component to a shaft. The axial force, which results from tightening the bolts, is translated into amplified radial forces that close the split bushing.

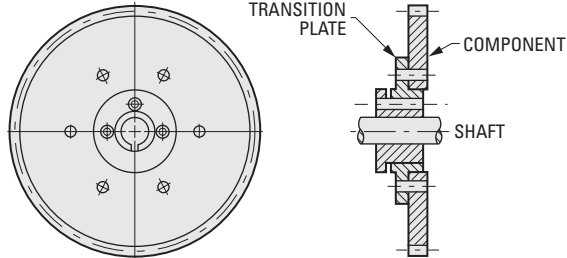

PREVIOUS METHOD

In this way, fastening of the component to the shaft is achieved. A disadvantage of this particular method is that the component must have a tapered bore.

A modification of this method, so that it can be used to fasten components with cylindrical bores, involves the use of a transition plate which contains the tapered bore.

However, the Shaftloc® design is the **ULTIMATE** in fastening methods for the following reasons:

Shaftloc® has only two parts:

A slotted outer sleeve and a slotted inner sleeve, both of which have hexagonal heads. The outer sleeve is cylindrical on its outside diameter, and threaded on its inside diameter. Conversely, the inner sleeve is threaded on its outside diameter, and cylindrical on its inside diameter. The thread is unique in that it is not symmetrical and that it creates a continuous inclined surface.

How Shaftloc® works:

The shallow angle of the thread produces large amplifications of forces, resulting in substantial torque transmission capability between the component and the shaft.

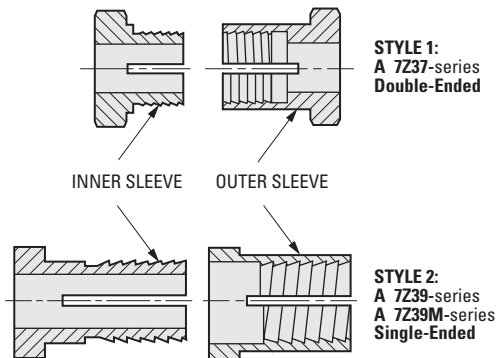

> DID YOU KNOW?

That you can see a video showing how the Shaftloc® rotating component fastener works and how it can benefit your application. It is located at: www.sdp-si.com/shaftloc



DISTINCT ADVANTAGES OF SHAFTLOC® OVER OTHER FASTENING DEVICES:

- Simplicity of design – few parts
- No marring of shafts
- Easy repositioning or synchronizing of rotating components.
- Ease of assembly
- Applicability to small shaft diameters
- Availability in all stainless steel construction
- Ability to be used for stationary breadboard or production structures
- Low-cost

Style 1: Double-Ended

When the two sleeves are threaded into each other with a component placed between them, tightening the sleeves will cause the outer one to expand and the inner one to contract.

Style 2: Single-Ended

When the two sleeves are threaded into each other and slipped into the component, tightening the sleeves will cause the outer one to expand and the inner one to contract.

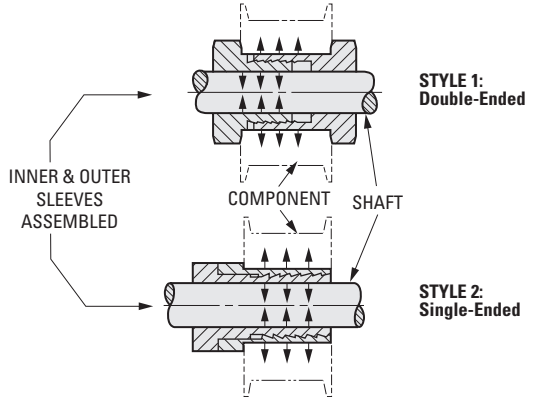

Style 3: Shaftloc® M-Type

Two-piece construction consists of a slotted sleeve and a nut, both of hexagonal shape. Used as a locking device for rigidly mounting mechanical components on a shaft. Tightening the nut next to the component causes the slotted sleeve to contract by gripping the shaft and clamping the part to the sleeve at the same time.

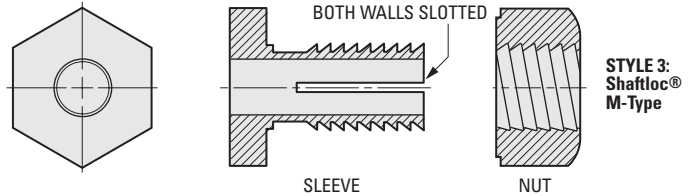

Style 4: Shaftloc® A-Type

Two-piece construction consists of a bolt and a nut which becomes a vibration-resistant fastener when the nut is tightened to embrace the component mounted to it. The two-piece unit uses the wedging action between the shallow thread inclines of the nut and bolt when the nut is tightened against the component mounted on the bolt.

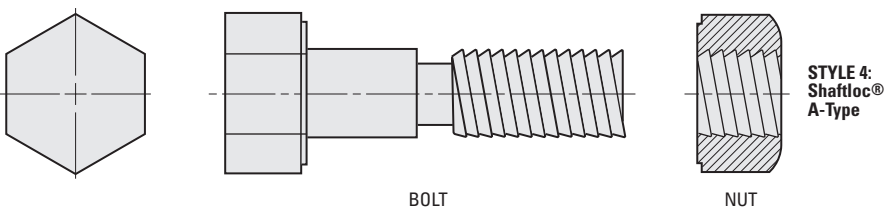

SINGLE-ENDED SHAFTLOC® SLEEVES



PATENTED
EASY ASSEMBLY
NO MARRING OF SHAFTS

PHONE: 516.328.3300 • FAX: 516.326.8827 • WWW.SDP-SI.COM

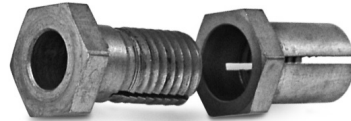
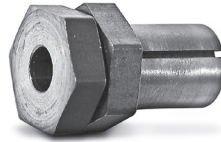

► **MATERIAL:**

416 Stainless Steel

► **SPECIFICATIONS:**

For Shaftloc® introduction and use, see page 4-3

For optimum performance, the clearances between the shaft, Shaftloc® and housing should not exceed .001"

Maximum torque capacity based on mating components being degreased before assembly with Shaftloc® coupling.

Single-Ended Shaftloc® Sleeves

Can be used with Precision Ground Shafting, Catalog Number A 7X 1-...

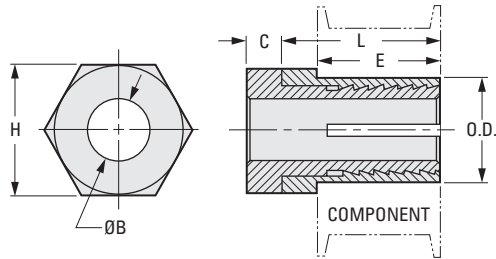

INCH COMPONENT

Catalog Number	B Bore +.001 -.000	O.D. +.000 -.001	H Hex Size	L	E	C	Max. Torque Capacity lbf in.
A 7Z39-0408	.125	.250	3/8	1/2	.375	1/8	15
A 7Z39-0612	.1875	.375	1/2	21/32	.500	5/32	55
A 7Z39-0812	.250	.375	1/2	21/32	.500	5/32	100
A 7Z39-0816	.250	.500	5/8	13/16	.625	3/16	200
A 7Z39-1216	.375	.500	5/8	13/16	.625	3/16	250
A 7Z39-1220	.375	.625	3/4	15/16	.750	7/32	250
A 7Z39-1624	.500	.750	7/8	15/16	.750	7/32	250