

# ANTI-BACKLASH GEARS • 96 PITCH



AGMA 10  
 .104 FACE  
 1/8, 3/16 & 1/4 BORE  
 20° PRESSURE ANGLE

PHONE: 516.328.3300 • FAX: 516.326.8827 • WWW.SDP-SI.COM



**> MATERIAL:**

- Gears** - 303 Stainless Steel  
 2024-T4 or -T351 Aluminum Alloy,  
 anodized before cutting.
- Hubs** - 303 Stainless Steel
- Springs** - 302 Stainless Steel, Spring Temper

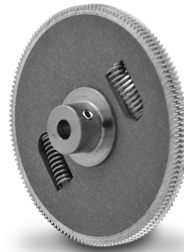

**> HUB STYLE: PIN OR CLAMP TYPE**

B Bore Selection		H Pin Type		C Clamp Type	
Code	Size	Code	Dia.	Code	Dia.
3	.1248 (1/8)	2	.312	3	.187
4	.1873 (3/16)	4	.375	5	.250
6	.2498 (1/4)	6	.437	7	.312

Available on special order:  
 14-1/2° P.A., teeth not listed, different  
 bore size, passivation for Stainless Steel.

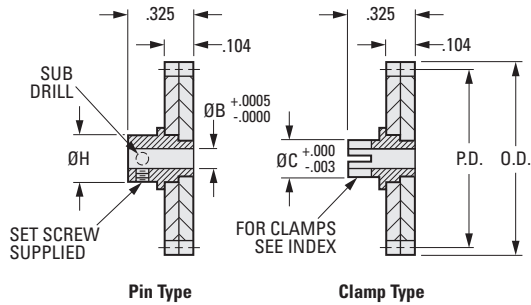

**INCH COMPONENT CATALOG NUMBER**

S 970  A-Z  H     P

- B Bore Code**
- .1248 (1/8) 3
  - .1873 (3/16) 4
  - .2498 (1/4) 6
- Hub Style Code** (See above)
- Pin Type 2, 4 or 6
  - Clamp Type 3, 5 or 7
- Material Code** - Gears
- 303 Stainless Steel -
  - 2024-T4 or -T351 Aluminum Alloy, anodized before cutting. **A**

**No. of Teeth Code**

No. of Teeth Code	No. of Teeth	P.D.	O.D.
130	130	1.3542	1.375
135	135	1.4063	1.427
140	140	1.4583	1.479
144	144	1.5000	1.521
145	145	1.5104	1.531
150	150	1.5625	1.583
160	160	1.6667	1.688
170	170	1.7708	1.792
180	180	1.8750	1.896
190	190	1.9792	2.000
192	192	2.0000	2.021
200	200	2.0833	2.104
210	210	2.1875	2.208
220	220	2.2917	2.313
230	230	2.3958	2.417
240	240	2.5000	2.521
250	250	2.6042	2.625
260	260	2.7083	2.729
270	270	2.8125	2.833
288	288	3.0000	3.021

Example:  
 S9703A-Z2H144AP is an Aluminum Pin Type  
 Anti-Backlash Gear with 144 Teeth and .1248 Bore.

- I
- R
- T
- 1
- 2
- 3
- 4
- 5
- 6
- 7
- 8
- 9
- 10
- 11
- 12
- 13
- 14
- 15
- 16