

> DESIGN:

The magnetic particle slip clutch uses a sealed, steel outer housing and permanent magnets arranged alternately (north and south poles) around a central hub.

The space between the housing and the magnets is filled with a ferromagnetic compound (hysteresis particles). The particles align themselves along the flux pattern between the steel housing and the magnets, creating a magnetic coupling between them. (See Fig. 1)

The torque rating is determined by the number of particles added. The clutches can be manufactured in the range from 2.82 to 39.55 N • cm. Because the coupling is magnetic, torque value remains stable over time, temperature and speed value.

> APPLICATIONS:

One of the applications is for paper feeding devices on scanners, copy machines and fax machines. Paper is an abrasive material. Pages often stick together and usually the thickness of the paper is different. The paper feeding device uses a powered roller to “urge” the top sheet off an infeed stack toward the interface between a second pair of rollers just beyond the urging mechanism. On the second pair, one of the rollers is powered; the second is unpowered, spring-loaded against the first and rides on a shaft linked to the chassis through the magnetic particle clutch. With no paper in the feeder mechanism, the clutch slips; when a single page is drawn between rollers, friction between the rollers and the paper remains high enough to maintain slippage and paper passes through the mechanism normally.

If two or more pages are drawn in, the coefficient of friction between the pages is not high enough to drive the unpowered roller. The slip clutch now acts as a drag brake holding back the lower roller. The roller stalls, preventing all but the top page from continuing through the feed device.

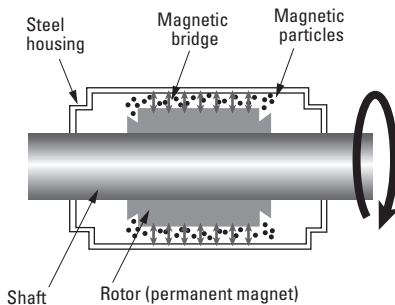

Fig. 1
Reversible Magnetic Particle Slip Clutch

- I
- R
- T
- 1
- 2
- 3
- 4
- 5
- 6
- 7
- 8
- 9
- 10
- 11
- 12
- 13
- 14
- 15
- A

ZERO MAINTENANCE
CONSTANT TORQUE LEVELS

PHONE: 516.328.3300 • FAX: 516.326.8827 • WWW.SDP-SI.COM



> MATERIAL:

Shell - Steel
End Caps - Plastic

> FEATURES:

Requires no power
Uses permanent magnets and magnetic particles
Long operational life
Sealed from contamination

> SPECIFICATIONS:

d Tolerances:
Fig. 1: +0.1/0
Fig. 2: +0.022/0
*D₁ Tolerance: 0/-0.033 (h8)

**Optional torques available only by special order.

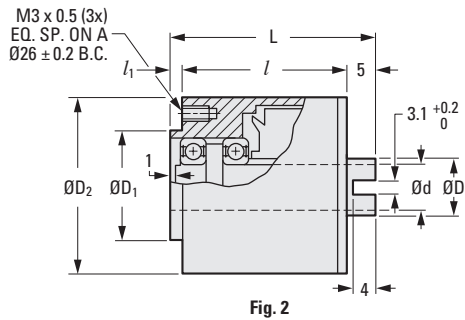
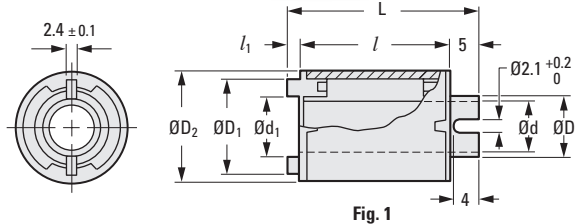
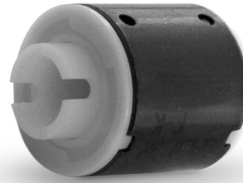

METRIC COMPONENT

Catalog Number	d Bore	d ₁	D Hub Dia.	D ₁ Hub Dia.	D ₂	l	l ₁ End Lgth.	L Total Lgth.	Max. Allowable Speed rpm	Torque		Weight kg
										± 10% Static N • m	Nominal Opt. Range** N • m	
Fig. 1 Plastic Bearings												
S90APLMP08030028	8	11	11	17	20	20	2.5	27.5	300	0.030	0.019 - 0.040	0.025
S90APLMP08060028	8	11	11	17	20	27	2.5	34.5	250	0.060	0.040 - 0.060	0.030
S90APLMP08120035	8	11	11	17	20	27	2.5	34.5	250	0.120	0.060 - 0.120	0.030
Fig. 2 Ball Bearings												
S90APLMS08099037	8	-	10	20*	32	30	2	37	400	0.099	0.070 - 0.099	0.120
S90APLMS08150037										0.150	0.099 - 0.150	
S90APLMS08199044										0.199	0.150 - 0.199	
S90APLMS08301044	8	-	10	20*	32	37	2	44	300	0.301	0.199 - 0.301	0.150

NOTE: When the slip clutch is to be subjected to any radial or axial thrust, use of the ball bearing design is required. Units should be used on horizontal shafts only.

I
R
T
1
2
3
4
5
6
7
8
9
10
11
12
13
14
15
A